

Kolbenkompressoren Serie LB

Piston compressors Line LB

- Robuste Grauguss-Ausführung des Verdichters
- Langlebig und geräuscharm dank niedrige Drehzahl
- Zuverlässig und bedienungsfreundlich durch Steuerung über automatischen Condor-Druckschalter

LB40 (3,0 kW)



Abb. SB4/S-200.LB40

- | | |
|--|--|
| <ol style="list-style-type: none"> 1. Druckbehälter
<i>tank</i> 2. Montageplattform
<i>platform</i> 3. E-Motor
<i>motor</i> 4. Riemenscheibe
<i>wheel</i> 5. Keilriemen
<i>belt</i> 6. Schutzgitter
<i>protection</i> 7. Druckschalter
<i>pressure control</i> 8. Manometer
<i>manometer</i> 9. Entlüftungsleitung
<i>air outlet pipe</i> | <ol style="list-style-type: none"> 10. Luftförderleitung
<i>air inlet pipe</i> 11. Luftausgangshahn (1/2")
<i>air out crane</i> 12. Sicherheitsventil
<i>safety valve</i> 13. Rückschlagventil
<i>return valve</i> 14. Kondensatablasshahn
<i>condensate valve</i> 15. Dämpfer
<i>supporting pads</i> 16. Druckminderer (2 x 1/4 ")
(nicht bei 100 l-Behälter)
<i>pressure reduction valve</i>
(not available on 100 l tank) |
|--|--|

Technische Daten SB4/S-....LB40 (3,0 kW)

Technical data

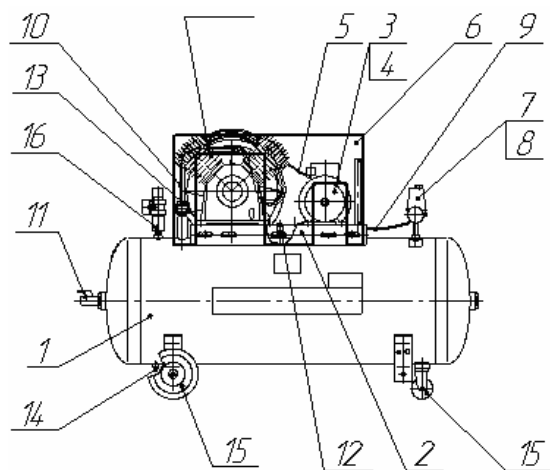
	Modell	
	SB4/S-100.LB40	SB4/S-200.LB40
Anzahl Verdichtungsstufen <i>compression stages</i>	1	
Anzahl Zylinder <i>cylinder</i>	3	
Drehzahl Verdichter min⁻¹ <i>rotation of compreesor</i>	1200	
Ölmenge, l <i>oil filling</i>	1,1	
Ansaugleistung, l/min (m³/h) <i>air displacement</i>	530	
Maximaler Druck, bar <i>pressure max.</i>	10	
Versorgungsspannung, V <i>voltage</i>	380	
Frequenz, Hz <i>frequency</i>	50	
Nennleistung des Motors, kW <i>motor power</i>	3,0	
Volumen des Druckluftbehälters, l <i>tank volume</i>	100	200
Abmessungen, mm Länge / <i>length</i> <i>dimentions</i> Breite / <i>width</i> Höhe / <i>height</i>	1130 500 880	1460 640 1150
Anschlussgröße des Hahns, Zoll <i>compressed air outlet, inch</i>	1/2	1/2 (1/4)
Gewicht, kg <i>weight</i>	100	140

Ausführung SB4/S-... fahrbare (auf 2 Räder und Füßen)
 Execution SB4/S mobile (2 wheels and pads)